

**Post-installed  
rebar connections:  
Safe designs as per  
EC2 and TR 069.**

**A white paper  
for structural engineers.**



# Contents.

## White paper post-installed rebar connections

---

<b>Reinforcements in reinforced concrete construction.</b> From discovery to post-installed connections.	<b>03</b>
<b>Post-installed rebar connections.</b> The current status quo.	<b>04</b>
Limitations as per EC2 part 1-1.	<b>06</b>
<b>Post-installed rebar connections as per TR 069.</b> A brief introduction.	<b>08</b>
<b>The new TR 069 design method.</b> Structure and contents.	<b>10</b>
Differences compared to EN 1992-1-1.	<b>11</b>
Designing post-installed, rigid connections.	<b>12</b>
Consideration of the bond-splitting theory.	<b>13</b>
<b>A comparison of design methods.</b> EC2 part 1-1, EC2 part 4 and TR 069.	<b>14</b>
<b>Solutions for post-installed connections.</b> A compact decision tool for structural engineers.	<b>15</b>
<b>fischer FiXperience.</b> Safely design post-installed rebar connections with the REBAR-FIX module.	<b>16</b>
<b>fischer Services.</b> From a single source.	<b>18</b>
<b>White paper summary.</b>	<b>19</b>

**White paper publisher:** fischerwerke GmbH & Co. KG, Klaus Fischer Straße 1, 72178 Waldachtal, Germany, T + 49 7443 12 – 0, info@fischer.de; Annika Armbruster (Project Management). **Design, Production & Layout:** Kresse & Discher GmbH, Content Marketing, Offenburg; Marcus Stradinger (Project Management), Astrid Paz (Graphic Design). **Text:** Oliver Ernst and Daniel Heiß (fischer), Dennis Müller and Marcus Stradinger (Kresse & Discher). **Photographs & technical drawings:** fischer (22), concrete image (p. 3), Alamy stock image (p. 3), WestPic / Adobe Stock (p. 13), Alexander Lindorf (p. 13). **Year of publication:** 2022

# Reinforcements in reinforced concrete construction.

## From discovery to post-installed connections.

Reinforced concrete is used for a **versatile range of applications**, from bridge and tunnel construction to producing bond beams and foundations as well as in floor or wall construction. This is primarily because the composite offers good tensile strength in addition to high compressive strength compared to unreinforced concrete, allowing bending and tensile loaded members to be realised.

The performance of iron in concrete was first discovered around the mid-19th century. The French gardener and entrepreneur **Joseph Monier** experimented by making plant pots for transportable orange trees with a

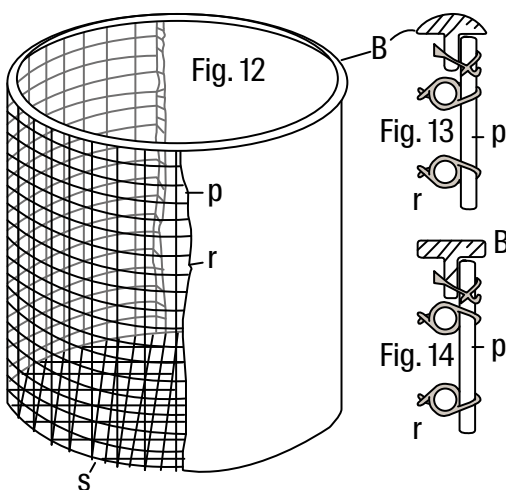

In his experiments, Joseph Monier was searching for a replacement for his non-permanent wooden plant pots. Drawings from the time serve as proof of this.

concrete mix. Upon realising that the containers made out of a pure concrete mix weren't durable enough, he added an iron mesh before pouring over a concrete mix. This moment would come to be known as the birth of iron reinforced concrete, now known as reinforced concrete.

### Reinforced concrete today

To this day, reinforcements are still mostly inserted before concreting in the form of bars and reinforcing mats on construction sites. Engineers in charge of planning take into account the building's force distribution before adapting the necessary reinforcements. The areas where the reinforcement ends and where it must be joined are therefore particularly important to the inserted reinforcements. The **end anchorages and overlap joints** therefore require the corresponding verification. The bar ends can be designed as straight bar ends, hooks, loops or with a welded transverse bar on end anchorages. This affects the length of the anchorage. Large concrete members often cannot be cast in one single step. The necessary starter bar continues through out the formwork in order to be able to connect the adjacent concrete section with the previous one in the resulting construction joints.



The French gardener **Joseph Monier** is considered to be the inventor of iron reinforced concrete, now known as reinforced concrete. In 1849 he created reinforced concrete for the first time and somewhat by chance.

### Force distribution in reinforced concrete elements

Concrete resists the compressive forces in reinforced concrete, while the tensile and flexural tensile forces are transferred onto the steel reinforcement (mostly in the form of mats or bars). The reinforcement is also used to carry compressive forces in components in compression.



# Post-installed rebar connections. The current status quo.

Subsequent structural changes often lead to changes to the structural system which the existing reinforcement have not been designed for. Missing reinforcements must be added for the new structural system. In these cases, the force-fit continuation of the reinforcement is associated with a great deal of effort involving exposing parts of the reinforcement in the existing member. **Costly and elaborate partial demolitions** are required if the subsequent continuation of the reinforcement is not included in the planning phase, for instance through a rebend connection, internal threaded headed fasteners or rebar couplers.

**Damages to existing connecting bars** can easily occur through traffic on the construction site, for instance. Bent bars cannot simply be bent back into place, as plastic deformations significantly reduce the steel's load-bearing capacity. Bars that could

present a nuisance during construction should therefore be placed at a later point in time, where possible.

There was therefore a great deal of interest in a reliable post-installed starter bar system involving a reasonable amount of work and a valid design basis. Post-installed rebar connections with approval have since been the solution. This involves bonding reinforcement bars with injection mortars. Over the past decades, post-installed rebar connections have become an essential component of construction projects. **Typical applications** include connecting new wall elements to existing concrete walls, floor slabs or concrete floors, foundation extensions as well as closing existing floor openings.

## Overlap joint vs end anchorage

Overlap joints help connect two reinforcement bars by overlapping the ends, thereby enabling an extension of the reinforcement bar to transfer tensile or compressive forces. If there are no forces in the reinforcement bars around the connecting interface, then end anchorages can be carried out without overlap.

In the past, structural engineers occasionally reached the limits of design when planning post-installed rebar connections with EC2 part 1-1.





Dr Jörg Asmus has been running an engineering firm in the Stuttgart region with his partner Prof Dr Eligehausen since 2004.



**“Both EC2 part 1-1 and TR 069 bridge the gaps in the renovation of reinforced concrete structures. Specialist training for installers as well as certifying businesses in addition to thorough planning have proven to be effective for proper execution.”**

**Dr. Jörg Asmus**

Managing Director of the IEA Engineering Firm in Stuttgart

# Post-installed rebar connections.

## Limitations as per EC2 part 1-1.

### Design as per EC2 part 1-1

The rules of reinforced concrete construction apply to post-installed rebar connections. Designs therefore follow **part 1-1 of EC2**. Although the necessary injection mortar systems require a **European Technical Assessment (ETA)**, until now this has always referred to EC2 part 1-1 in terms of design. Designing post-installed rebar connections with the help of an injection mortar system is therefore accordant to designing cast-in, straight bars.

### Specific limitations

As a result of this process, design guidelines also remained limited in terms of the **bond stress  $f_{bd}$** . In principle, reinforcing bars can be embedded in mortar without or with connecting reinforcement. In the former case this involves classic end anchorages, in the latter, it involves **overlap joints**. The ETAs however explicitly stipulate overlap joints on the rebar provided in the existing member based on EC2 part 1-1 for starter bars

in tension loaded connections.

Waiving the lap rebar, for instance by utilising the concrete's tensile strength by applying the **anchor theory**, is not permitted as per EC2 part 1-1.

Such connections are only regulated for up to  $3 \times 3 = 9$  anchors according to **EN 1992-4**, in other words, the anchor theory. More on this later. If a rigid reinforced concrete connection was required, it was previously formed using an overlap joint, which presented structural engineers with several practical challenges, as they had to consider the effects on the construction process, cost efficiency and occupational safety on the construction site within the standard's narrow specifications.

**An overview of the limitations of post-installed rebar connections**

**Designing** post-installed rebar connections as per EN 1992-1-1 is accordant to designing cast-in, straight bars.

**Costly and elaborate partial demolitions** may be required in order to create a rigid rebar connection.

**Very large, unfeasible anchorage lengths**, as only straight bar ends without hooks or loops can be used on post-installed rebar connections.

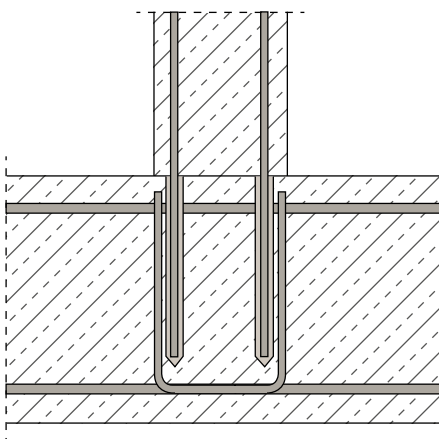

Schematic figure depicting a base plate or foundation including an existing connecting reinforcement.

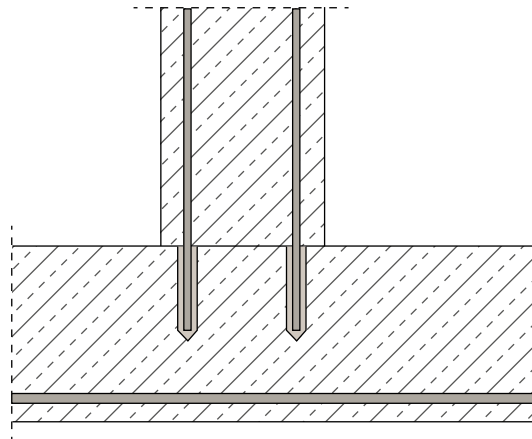

Schematic figure depicting a base plate without an existing starter bar.



## Obstacles on the construction site

Occasionally, starter bars may have been placed in the wrong position or are missing entirely in the existing member. This is due to unplanned changes or poor execution. If the work is to be continued in compliance with EC2 part 1-1, then the corresponding area of the rebar connection must be exposed for

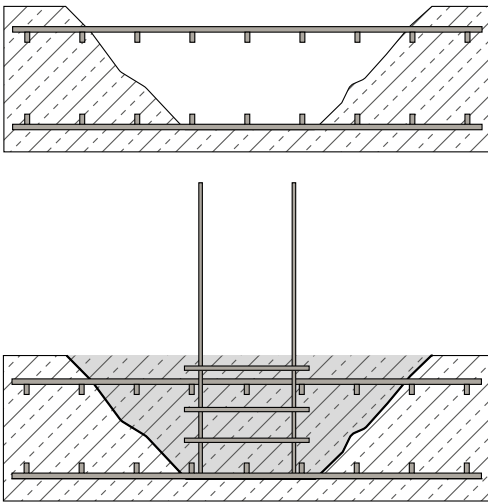

Until recently, the connection area had to be exposed before the connecting reinforcement could be used in order to be able to execute a post-installed overlap joint in compliance with EC2 part 1-1, which cost a great deal of time and money.

the rebar to be reconnected in order to realise a compliant lap. Under the previous regulation, **rigid connections** without overlap joints were not regulated as post-installed rebar connections by regulatory requirements.

## Particularities of planning post-installed rebar connections

As mentioned above, **designing** post-installed rebar connections as per EN 1992-1-1 is accordant to designing cast-in bars, however only straight bar ends without hooks or loops can be used. Inserting post-installed rebar mats is also not possible, which can lead to **very large bar embedment depths**. As a rule, creating post-installed rebar connections with injection mortars should only be carried out by trained members of staff. In Germany, **companies and craftsmen carrying out this work** must be certified.

### Typical errors in executing post-installed rebar connections:

- The actual existing reinforcement does not correspond to the existing reinforcement assumed in calculations.
- Staff on the construction site have not been sufficiently trained.
- The existing rebar was damaged or drilled through during the drill process
- The connection joint is not sufficiently roughened up.
- The drill hole has not been cleaned sufficiently.
- Air bubbles were trapped while filling the drill hole with injection mortar.

The traditional method of installing post-installed rebar connections as per EC 2 part 1-1 involved several pitfalls for structural engineers.



# Post-installed rebar connections as per TR 069.

## A brief introduction.

In new builds, overlap joints are executed through a rigid connection for walls, floors or columns by installing **L or u-shaped reinforcing bars** at a precisely defined location.

### Require rigid concrete connections?

Here are two practical examples: Only **columns under compression** are regulated by previous ETAs for post-installed rebar connections and according to designs as per EC2 part 1-1. These kinds of structures rarely occur in reality, however, so if a column has a rigid connection,

an end anchorage is insufficient. Creating a lap is necessary as per EC2 part 1-1.

To name another example, the specific regulations of EC2 part 1-1 exclusively cover articulated floor/wall connections when **mounted 'floor to wall'**. This leads to a certain limitation of structural engineers' fields of application.

**i** The new EOTA1 Technical Report TR 069 permits the design of post-installed, rigid rebar connections that do not have to be carried out as overlapping joints.

1) European Organisation for Technical Assessment



A post-installed rebar on a construction site.

### Missing existing rebar for overlap joints

If there is no existing reinforcement on-site that can be used for overlap joints, then planners had to resort to using the **anchor theory** (EC2 part 4) for a lack of alternatives until now. This does not come without its issues, as this approach fundamentally deviates from the **rebar theory** (EC2 part 1-1) both in terms of load direction and load distribution mechanism as well as minimal concrete cover or permissible embedment depths. As such, there is a risk that the reinforcement and anchor theories are applied incorrectly. The various deformations to be expected should also be taken into account.



Post-installed rebar connections play a key role, particularly on large construction sites such as the prestigious 'Le Grand Paris' métro project.



The network expansion of the 'Le Grand Paris' construction project in the heart of the capital is expected to be completed by 2030.



# The new TR 069 design method.

## Structure and contents.

Based on the previous approach as per EC2 part 1-1, it was already possible to carry out post-installed rebar connections as well as defined connections in the form of an end anchorage. The new EOTA Technical Report **TR 069** now additionally allows rigid rebar connections to be implemented as end anchorages across Europe, which no longer require an overlapping reinforcement into the existing member. The ensuing new applications can generally be categorised into **three areas**:

1. Column or wall to foundation or footing slab.
2. (Floor) slab or beam/joist to wall.
3. Beam or joist to column.

### Application areas of TR 069

The design process described in TR 069 is applicable for moment-resisting connections subjected to **static and quasi-static loading**. Seismic or fatigue actions as well as fire exposure are not covered so far, however.

This Technical Report covers both ultimate and serviceability limit states. Local load distribution in concrete members is verified as per TR 069, while evidence of load transmission in the member is to be provided separately as per EN 1992-1-1.

Furthermore, designs as per TR 069 only consider **tensile forces**. Evidence against steel failure, concrete cone and bond-splitting failure must be provided. **Shear forces** tend to be transferred by the roughed up concrete joint. Alternatively, direct supports can be formed in the shape of a shear lug or a partial support on a wall.

### Design concept as per TR 069

The resulting design value of the load-bearing capacity  $R_d$  as per TR 069 is obtained from the load-bearing capacities of the individual failure modes (steel, concrete and splitting failure). The minimum load-bearing capacity value is relevant.

$$R_d \leq \min(N_{Rd,y}; N_{Rd,c}; N_{Rd,sp})$$

This must correspond to the minimum design value of the action  $E_d$ .

$$E_d \leq R_d$$

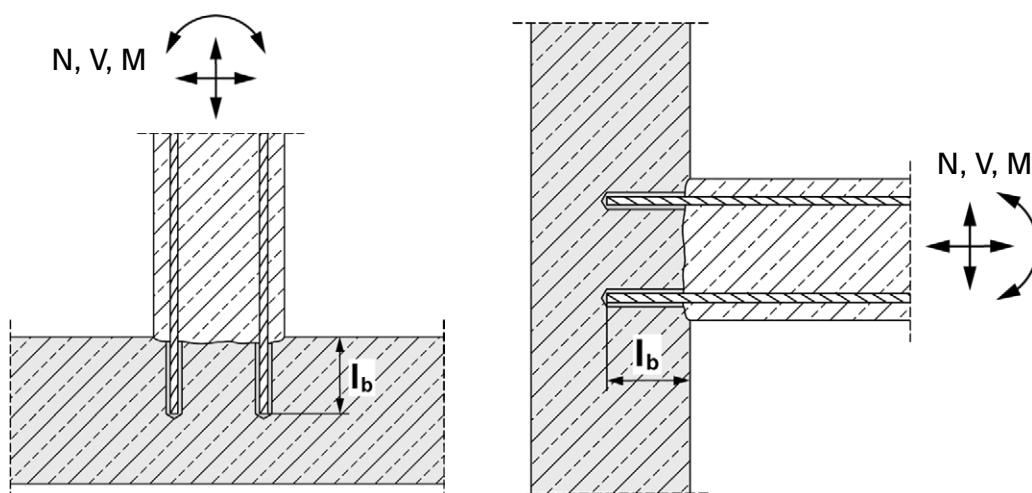

The design concept described in TR 069 covers many types of applications, including rigid rebar connections such as columns on a foundation (left figure) and beams on a column (right figure).



# The new TR 069 design method.

## Differences compared to EN 1992-1-1.

TR 069 permits designs of **moment-resisting connections** with post-installed rebar connections. However, the injection system must explicitly demonstrate qualification based on the **European Assessment Document (EAD 332402-00-0601)**.

Another difference between TR 069 and EN 1992-1-1 is that the new design method regulates **strength classes (concrete strength classes)** from C20/25 to C50/60. As a result, low-strength concrete C12/15 or C16/20 is not permitted in designs as per TR 069.

The centrepiece of the new TR 069 design method is the fact that **no connecting reinforcement is needed for load transmission** in the existing member. The load distribution mechanism is obtained through use of the concrete tensile strength. Evidence of concrete cone failure (as per anchor theory) must be provided by way of calculation. Another new aspect is that TR 069 recognises the

**bond-splitting behaviour** of embedded reinforcing bars. The **concrete cover** plays a significant role in verifying the bond-splitting failure in terms of load-bearing capacity.

Reinforcing bars with a thinner concrete cover demonstrate significantly lower bond stress and more brittle failure than reinforcement bars with thicker concrete cover. This is due to splitting of the concrete cover in members with a thinner concrete cover. Reinforcing bars with a thicker concrete cover fail via pull-out.

### Design and verification according to TR 069

While EC2 part 1-1 recognises the transfer of shear forces through bars based on the reinforcement ratio, this is not the case with TR 069.

### Design as per TR 069 has its advantages compared to design as per EC2 part 1-1 in the event of:

- thicker concrete covers
- thinner member thickness/ lower possible embedment depths
- no pre-existing connecting reinforcement required

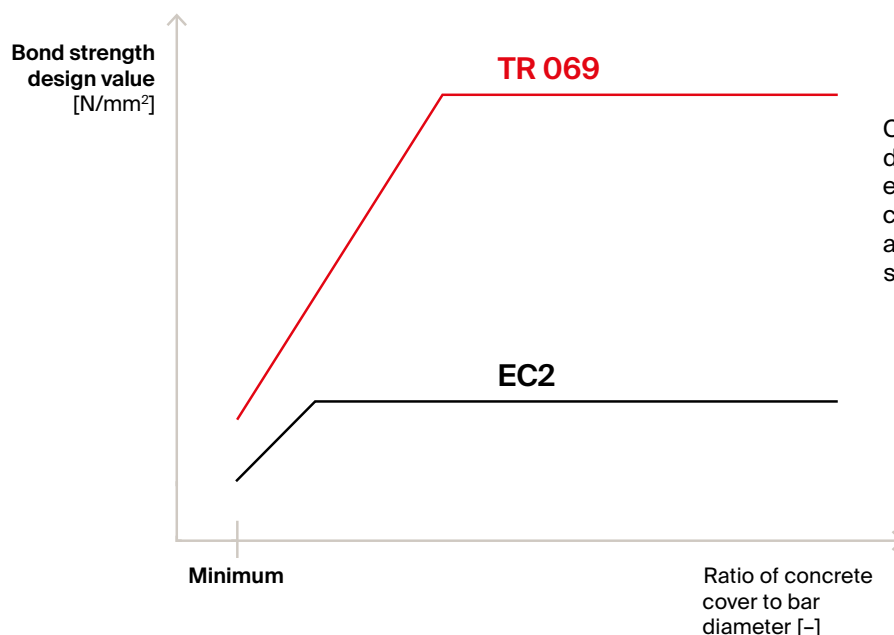

Comparison of bond strength design values depending on existing concrete cover for cast-in or post-installed bars as per EC2 as well as post-installed bars as per TR 069.

# The new TR 069 design method.

## Designing post-installed, rigid connections.

As mentioned above, it was possible to create post-installed, rigid rebar connections in the past, provided a lap could be carried out in the existing member with the existing reinforcement which often involved large embedment depths.

However, end anchorages without lap were only verifiable if no axial forces remained in the bar at the point of the connection.

For the first time ever, TR 069 now offers the opportunity to create **post-installed, rigid rebar connections** without an existing rebar for the purpose of lapping. This is made possible through a combination of verification as per **EN 1992-1-1** (rebar theory) and **EN 1992-4** (anchor theory). The necessary verification is illustrated in an overview in the below table.

### Using the concrete's tensile strength

It is possible to utilise the **concrete's tensile strength** to the fullest extent and to apply it to the design in accordance with TR 069 as well as EN 1992-4. In order to prevent brittle failure when providing verification as per TR 069, it is advisable to place the embedment at a sufficient depth so that **steel yielding** as a relevant, decisive **failure criteria** is to be expected in the embedded rebar.

In addition to evidence against steel yielding under TR 069 evidence must also be provided against concrete cone failure as well as bond splitting. The minimum anchorage length as per EC2 part 1-1 must also be adhered to and verified. **Qualified injection systems** in the form of a relevant ETA are required to allow evidence to be provided in accordance with TR 069. EAD 332402-00-0601 stipulates the tests necessary for this purpose.

### Limitations of applying TR 069

The new Technical Report explicitly does not cover the load transmission in the existing members nor the transfer of shear forces. The latter is to be transferred onto the roughened interface or a direct support, for example, and must be verified. However, the verification of the local load distribution is fulfilled and the necessary anchorage length is determined.

Failure mode	Resistance	Verification required	
		Tensioned rebar group	Most unfavourable tension loading on single rebar
Steel yielding resistance	$N_{Rd,y} = N_{Rk,y} / Y_{Ms}$	Yes	No
Concrete cone resistance	$N_{Rd,c} = N_{Rd,c} / Y_{Mc}$	Yes	No
Bond-splitting resistance	$N_{Rd,sp} = N_{Rk,sp} / Y_{Msp}$	Yes	Yes



# The new TR 069 design method.

## Consideration of the bond-splitting theory.

The tensile force in the rebar and the transfer through the injection mortar to the surrounding concrete results in splitting forces in the concrete. This is due to **deviating forces** caused by the rebar and its ridges in the concrete. If there is no reinforcement to resist the splitting forces this must be taken into account in the design.



Ribbed B500 reinforcing bar on the construction site.

**Splitting forces** are often relevant in anchorages close to the edge (thin concrete cover) in particular.

Evidence of bond-splitting failure is provided for this purpose, which calculates the **bond-splitting stress**  $T_{Rk,sp}$  on the embedded skin surface of the rebar.

Factors for the applied injection mortar consider the concrete strength, the rebar diameter,

the concrete cover of the transverse reinforcement as well as the transverse compressive stress perpendicular to the axis of the rebar and the anchorage length in the calculation of  $T_{Rk,sp}$ . These factors are individually determined for each system requiring approval for the post-installed, rigid rebar connections and can be found in the product's respective ETA (European Technical Assessment).

The bond-splitting stress is capped by the **bond stress**  $T_{Rk,ucr}$  for non-cracked concrete. This ensures that the load bearing capacity of the rigid rebar connection does not exceed the load bearing capacity of an anchorage.

After the necessary anchorage length has been determined with verification for concrete cone failure and bond-splitting failure, a subsequent test is carried out to ensure that the determined anchorage length is not shorter than the minimum anchorage length  $l_{b,min}$  as per **EN 1992-1-1**. This fulfils verification of the local load distribution. The load transfer from the rigid connection into the existing member is to be evidenced separately similar to the **anchor theory (EN 1992-4)**.

### Components of bond failure

Bond failure can be divided into splitting crack failure, in other words, failure caused by cracking of the concrete (in thin concrete cover) as well as shear failure (shearing of the concrete consoles in larger edge distance) with the subsequent slipping of the rebar.

**TR 069** allows planners to provide evidence of a rigid rebar connection with a relatively low embedment depth (therefore also in relatively thin members) and without connecting reinforcement bar in the existing member.

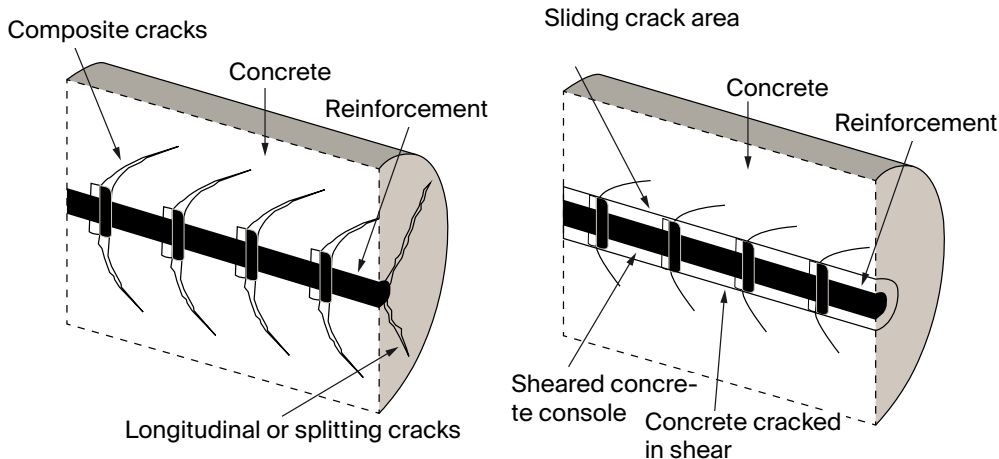

If the concrete cover or edge distance is increased, the splitting crack failure (left figure) of a cast-in rebar transfers into shear failure (right figure). If reinforcing bars are anchored close to the edge or with a thin concrete cover, this alters the bond-splitting behaviour. This is now recognised in design verification as per TR 069.

# A comparison of design methods.

Nowadays, post-installed rebar connections can be created for many different applications as per EC2. Embedding the reinforcing bars relatively short is often sufficient, particularly if a small floor opening requires closing. Points that require clarification include whether shear loads and additional tensile forces exist or whether a rigid moment connection is required or if there is a continuing reinforcement in the existing member. These aspects will affect which design method can or must be used.

## Rebar theory

The loads in post-installed reinforcing bars are transferred through struts in the concrete into the reinforcement, in which case the post-installed bars are treated as cast-in bars. According to **rebar theory (EN 1992-1-1)**, reinforcing bars can be post-installed with and without connecting reinforcement.

## Anchor theory

**EN 1992-4** only utilises the tensile strength of the concrete. The bond strength are significantly higher than they are according to rebar theory and embedment depths of 4 to 20 times the diameter of the bars are covered. Unlike in rebar theory, shear loads can be transferred in addition to tensile loads.

## TR 069

**TR 069** bridges the gap between rebar and anchor theory and uses elements of both design approaches, allowing post-installed, **rigid rebar connections** to be carried out even in cases where there is no starter bar in the provided existing concrete member and only relatively short embedment depths are possible. This is possible as the bond strength is significantly higher than it is according to rebar theory.

## Detailed anchor theory approach

According to anchor theory, separate verification must be provided by load direction for tensile loads (verification for steel failure, combined pull-out and concrete cone failure) as well as for shear loads (verification for steel failure, pry-out and concrete edge breakout). Finally, additional evidence of interaction is required that takes into account that tension and shear loads may occur simultaneously. However, to date, anchor theory does not cover fastening one concrete member to another concrete member.

Design method characteristics (comparative questions)	Post-installed rebar connection (EN 1992-1-1)	Anchor connection (EN 1992-4)	Rigid post-installed rebar connection (TR 069)
Is a starter bar/continuing reinforcement required?	Yes	No	No
What is the required edge spacing for high tensile loads?	Very low	Large	Large
How large is the expected displacement?	Very low	Low	Low
How large is the necessary embedment depth for an effective anchorage under tensile load?	Quite large	Not very large	Not very large
How large is the necessary member thickness (towards the bar axis)?	Quite large	Not very large	Not very large
Do installers need to be certified?	Yes (in Germany)	No	No
Can shear loads also be transferred?	No, but can be transferred through interface roughness	Yes, through the anchor	No, but can be transferred through interface roughness
Are linear or free bar layouts possible according to this design code?	Yes	No, max. 9 anchors	Yes
What is the minimum concrete grade?	C12/15	C12/15 (anchor ETA not yet applicable)	C20/25
Does this design method differentiate between cracked and non-cracked strength?	No	Yes, reduced resistance in cracked concrete	Yes, reduced resistance in cracked concrete
Are concrete-concrete connections regulated?	Yes	No	Yes



# Solutions for post-installed connections.

## Compact decision-making tools.

fischer offers various **ETA approved systems** to create post-installed rebar connections.

### fischer injection mortars

The FIS RC II injection mortar is an easy-to-use solution at an attractive price. This mortar is unbeatable even in low temperatures and for deep embedment depths. Rebar connections can be carried out with a bar diameter of up to 40 millimetres with the high-quality FIS EM Plus epoxy mortar - including in diamond-drilled holes - or alternatively with the FRA rebar anchor, requiring little effort to clean the drill hole.



Injection mortar cartridges of the FIS RC II and FIS EM Plus injection mortars.

#### Checklist for selecting your injection system

- ✓ Is a connecting reinforcement available?
- ✓ Is it known? Will a reinforcement scan of the existing reinforcement be carried out?
- ✓ Does the anchorage need to be placed close to the edge?
- ✓ Is it a rigid connection? Are the internal forces known?
- ✓ Is the existing member thin? (Deep embedment depth not possible)

Designation injection mortar	FIS RC II	FIS EM Plus	
European Technical Assessment	ETA-22/0502	ETA-17/1056	ETA-22/0001
Connection + verification as per EN 1992-1-1	End anchorage, overlap joint, cover envelope line of tensile force	End anchorage, overlap joint, cover envelope line of tensile force	-
Connection + verification as per TR 069	-	-	Rigid connection without overlap
Bar diameters	Ø 8 - 32 mm	Ø 8 - 40 mm	Ø 8 - 40 mm
Rebar anchors	FRA M12 - M24	FRA M12 - M24	-
Maximum embedment depth	2,000 mm	2,000 mm	2,000 mm
Installation temperature in the base material	-10° C bis +40° C	-5°C to +40°C	-5°C to +40°C
Minimum curing time	12 h - 35 min.	200 h - 5 h	200 h - 5 h
Hammer drilling	Yes	Yes	Yes
Hollow drilling	Yes	Yes	Yes
Diamond drilling	No	Yes	No
Dry and wet drill hole	Yes	Yes	Yes
Water-filled drill hole	No	No	Yes
Drill hole cleaning in case of hammer drilling	Blow out 2x, brush 2x, blow out 2x	Blow out 4x	Blow out 2x, brush 2x, blow out 2x
100-years service life	Yes	Yes	Yes
Application under seismic exposure	No	Yes	No
Application under fire exposure	Yes	Yes, R30 - R240	No

Which mortar suits your application? Our overview table compares various performance criteria of fischer injection systems.

# fischer FiXperience.

## Safely design post-installed rebar connections with the REBAR-FIX module.

Depending on the on-site options and requirements, the **REBAR-FIX** programme enables verification in line with various standards and guidelines. In addition to **EC2 Teil 1-1** for end anchorages, curtailment of the longitudinal tension reinforcements and overlap joints, verification for rigid connections without continuing reinforcements in existing members is also possible as per **EOTA TR 069**. The software also includes an engineering method (ENSO) for several further specialist cases, providing the right software solution for almost any potential design situation

In line with our own perception of being an **all-in-one system provider**, we support structural engineers with planning and designing various connection various connections arrangements concerning post-installed rebar connections.

### Create verifiable proof

The **REBAR-FIX** module is one of

the software **FiXperience** suite. It enables the simple and reliable design of post-installed rebar connections in reinforced concrete construction. This allows you to choose between different connections such as slab/slab with bearing, slab/wall, wall/wall or wall/foundation. Depending on the scenario, the tool subsequently offers clear connection situations based on various guidelines, allowing you to generate quick and secure verifiable proof for post-installed rebar connections.

### Further REBAR-FIX advantages

In addition to the above-mentioned features, the software also takes into account **fire resistance verification** as per the European EN 1992-2 standard as well as **structural verification** as per EN 1992-1.



**REBAR-FIX**

Try out the REBAR-FIX module in the fischer FiXperience software suite free of charge now!

Go to FiXperience



**I** With **REBAR-FIX** fischer offers an innovative programme for designing post-installed rebar connections in reinforced concrete construction that also enables verification as per TR 069.





Dr Christian Schlenk has been working for fischer in various roles at the production site for chemical fixing systems in Denzlingen for over 20 years.

**“We develop efficient and user-friendly system solutions for post-installed rebar connections. In doing so, we’re contributing to simple installation while also offering consultation services as well as our own design software.”**

**Dr Christian Schlenk**

Head of Development at fischer’s Chemical Business Unit

# fischer Services. From a single source.

Our **Technical Advice Experts** are available through all channels from Monday to Friday, by telephone, email and chat. **Structural engineers** can get competent support on queries such as designing anchors and post-installed rebar connections in reinforced concrete structures. fischer offers product, application and certification training also on post-installed rebar connections and provides certified fastening knowledge. We keep numerous users and engineers up to date through newsletters, mail and personal contact.

## Specialists in the field

Got a problem on your construction site? Our **fischer experts** are happy to support you on-site. We offer advice and support with the professional calculation and execution of post-installed rebar connections. Our experts will advise you on complex application scenarios such as missing existing reinforcements. Together we determine post-installed rebar solutions there and then that comply with applicable design codes.

## fischer Academy

We have been offering seminars for professionals in the construction industry for over 30 years.



The modern fischer Academy in Waldachtal.

The **fischer Academy** has dedicated trainers who understand their 'trade'. All state-of-the-art training sessions provide information on current national and European standards and guidelines as well as statutory provisions and their implementation during planning and processing. Our trainers complete **theoretical and practical** training and development sessions year after year to guarantee a high standard of quality. And the best part: You alone decide whether the training takes place at our Academy or through OnlineSeminars.

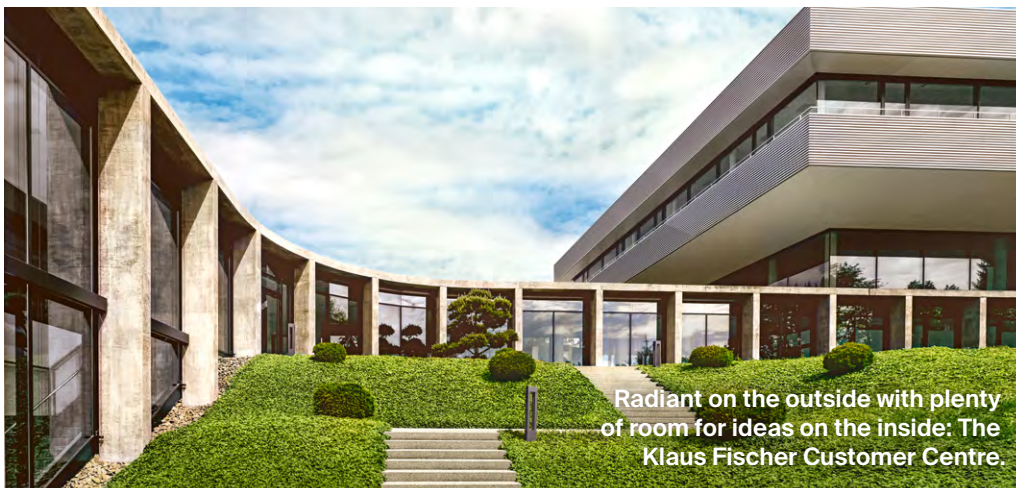

Radiant on the outside with plenty of room for ideas on the inside: The Klaus Fischer Customer Centre.

Training for structural engineers:

[www.fischer.co.uk/en-gb/training](http://www.fischer.co.uk/en-gb/training)

Go to fischer's OnlineSeminare



Our Technical Advice Experts are happy to help!  
Contact fischer now.

T +49 7443 12- 4000

[support@fischeracademy.com](mailto:support@fischeracademy.com)

# Summary.

## White paper summary. Post-installed rebar connections.

Post-installed rebar connections installed with injection mortars have proven to be effective in everyday construction in the recent past and are now used on both new builds as well as during construction on existing buildings. Typical applications include connecting new wall plates to existing concrete walls, floor slabs or concrete floors, foundation extensions as well as closing existing floor openings.

### Previous design as per EC2 part 1-1

For a long time, the design of post-installed rebar connections using an injection system was carried out according to the regulations of reinforced concrete construction similar to the rules of cast-in, straight bars, which entailed limitations. This design approach was particularly limited in terms of the bond strength  $f_{bd}$ . In addition to this, the ETAs based on EC2 part 1-1 for starter bars in rigid connections explicitly stipulated laps on the provided reinforcement in the existing member. Structural engineers occasionally tried to utilise the concrete's tensile strength according to anchor theory (EC2 part 4) in order to be able to do without an overlapping reinforcement. However, this combination of rebar and anchor theory is not permitted as per EC2 part 1-1 or part 4. According to previous regulations, rigid connections without overlap joints were not covered as post-installed rebar connections by regulatory requirements, which meant that a new design method was needed.

### Introduction of TR 069

As of October 2019, TR 069 permits the design of post-installed, rigid rebar connections that do not have to be carried out as overlapping joints. The new design method covers rigid connections under static and quasi-static loading.

The TR 069 design concept also covers both ultimate and serviceability limit states. Typical applications include rigid moment connections such as columns on a foundation and beams to a column. The following evidence is to be provided as per TR 069: Steel yielding, concrete cone failure and bond-splitting failure. The minimum embedment depth as per EC2 part 1-1 must also be considered. A relevant ETA is essential to being able to provide observation and verification as per TR 069. The ETA also confirms the qualification of the injection system in terms of the bondsplitting capacity.

### Help with selecting injection mortars

Planners can obtain key information on qualified mortar systems and can determine the necessary anchorage lengths with fischer's REBAR-FIX design software.



[www.fischer-international.com](http://www.fischer-international.com)



**fischer's focus:**

fixing systems

Automotive

fischertechnik

Consulting

Electronic Solutions

---

**fischerwerke GmbH & Co. KG**  
Klaus-Fischer-Straße 1 · 72178 Waldachtal  
Deutschland  
T +49 7443 12 - 0  
[www.fischer-international.com](http://www.fischer-international.com) · [info@fischer.de](mailto:info@fischer.de)

**fischer Austria Gesellschaft m.b.H.**  
Wiener Straße 95 · 2514 Möllersdorf / Traiskirchen  
Österreich  
T +43 2252 53 - 730 · F +43 2252 53 - 145  
[www.fischer.at](http://www.fischer.at) · [office@fischer.at](mailto:office@fischer.at)

This publication represents general, non-binding information. The content reflects the view of fischer at the time of publication. Although the information was created with the utmost diligence, there is no claim to its accuracy, completeness and/or topicality. In particular, this publication cannot take into account the particularities of individual cases. The reader is therefore personally responsible for its use. Any liability is excluded. All rights, including the duplication of any parts, are reserved by fischer, insofar as the rights in question are attributed to fischer.

---